

SMERIGLIATRICE VERTICALE VERTICAL GRINDER

SM43N

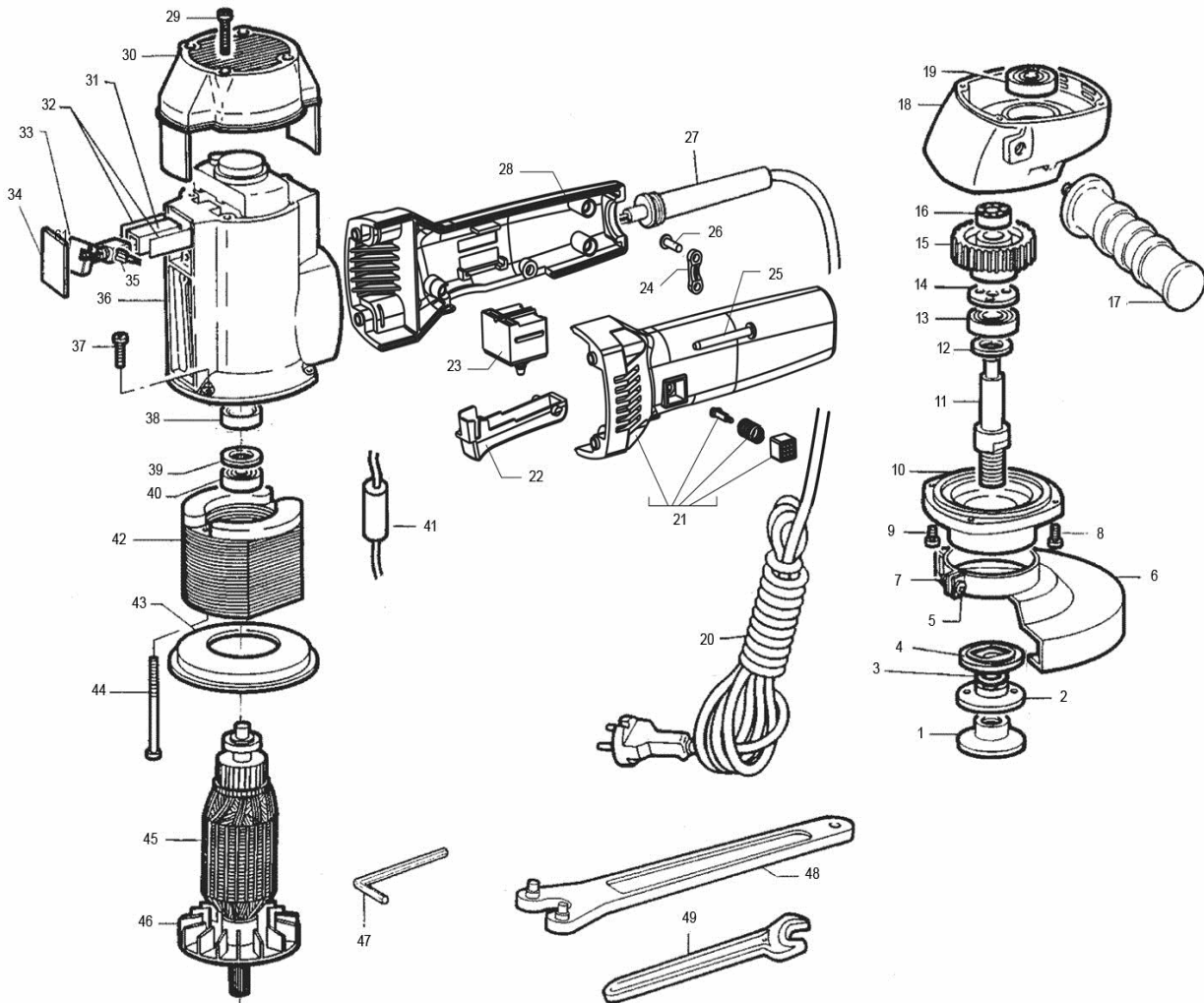

ID	ITEM	DESCRIPTION
001	924.24	CONIC NUT FOR VULKOFIX
002	934.092	LOCKING WHEEL NUT
003	9.243	STEEL WASHER d42 x 22,5 s 0,4
004	936.092	SUPPORT WHEEL NUT
005	9.678	SCREW M6 x 25 T.B.E. 12K BURNISHED
006	82.49	PROTECTION
007	9.527	NUT M6
008	9.616	SCREW M5 x 14 TC + C/D STEEL 8.8 T.P.
009	9.618	SCREW M4 x 20 T.C.C. 8G BURNISHED
010	331.85	FLANGE
011	511.82	SPINDLE SHAFT
012	333.038	d 28x15 s 0,3 STEEL WASHER
013	9.26/10	BEARING 6202 ZZ-C3
014	351.038	BEARING LOCKING FLANGE
015	52.82	WHEEL (Z38)
016	9.66	ROLLING BEARING TOR NK 9/12
017	81.326	COMPLETE SIDE HANDLE WITHOUT SPANNER
018	32.82	GEAR BOX
019	9.25/10	BEARING
020	9C2X4,0N003	CABLE 2x4 (without plug) H 07
020	9C2X1,0N403	CABLE 2X1 (plug 4) +CAP201/4,2 H 07
021	441.315	HALF-HANDLE LEFT
022	38.286	SWITCH BUTTON (clamp open/close)
023	45.284/UL	SWITCH 8(8) max 250V
024	442.55	CABLE CLAMP
024	444.14	CABLE CLAMP NYLON
025	9.687	SCREW 4,2x31 (8x1"1/4)T.C.C.
026	9.660	SCREW 3,9x16 (7x5/8") T.C.C.
027	421.40	RUBBER HANDLE LT2 B.T.
027	42.40	CABLE SLEEVE LH/GM/GP/SSPF
028	44.315	HALF-HANDLE RIGHT
029	9.682	SCREW 4,2x38 (8x1"1/2)T.C.C.
030	34.82	MOTOR BODY COVER
031	46.40	BRUSH HOLDER
032	48.82	RECTANGULAR PLATE FIB. 16,5x13,5 s1,5
033	47.70	BRUSH
034	481.24	RECTANGULAR PLATE FIB. 32 x 16 s 2
035	9.1346	FASTON FEMALE 2,8x0,8
036	31.82	SM43 MOTOR BODY
037	9.616	SCREW M5 x 14 TC + C/D STEEL 8.8 T.P.
038	78.82	RUBBER BEARING CAP 9405
039	9.309	STEEL WASHER d22 x 15,2 s 0,3
040	9.41/10	BEARING SKF 609 ZZ-C3
041	9.1505	CONDENSER CIL. MOD. MKT70 220 nF-K 250V
042	2.82/048	STATOR (V.48)
042	2.82/072	STATOR (V.72)
042	2.82/220	STATOR (V.220)
042	2.82/240	STATOR (V.240)
043	73.82	AIR BULKHEAD
044	9.652	SCREW 4,8x57 (10x2"1/4)T.C.C.
045	1.82/220	ROTOR (V.220)
046	15.82	FAN 18 BLADES
047	9.1395	ALLEN SPANNER 5mm
048	836.24	SPANNER
049	83.13	SPANNER mm 17